

DX Coils

Heatcraft[®] heat transfer
coils

by **LUVATA**

Contents and Nomenclature

Nomenclature.....	1
Evaporator Coil Types	
EN.....	2
EF.....	2
ER.....	2
EJ.....	3
EK.....	3
Evaporator Construction	
Connections.....	4
Tubing.....	4
Headers.....	5
Tube Supports.....	5
Coil Case.....	5
Fins.....	6
Engineering	
Liquid Overfeed Evaporators.....	7
General Formulas.....	7
Basic Vapor Compress Cycle.....	8

Nomenclature

5	E	N	14	06	C	24.00	x	144.00
5 = Tube O.D.				06 = Rows Deep				
E = Coil Type				C = Fin Design				
N = Circuiting				24.00 = Fin Height (in)				
14 = Fins Per Inch				144.00 = Finned Length (in)				

Tube Outside Diameter

3 = 0.375"
4 = 0.500"
5 = 0.625"

Coil Type

E = Evaporator

Circuiting

N = Normal
 F = Face Control
 R = Row Control
 J = Interlaced
 K = Interlaced Face Control

Fins Per Inch - 4 to 24

Rows - 1 to 12 (Consult factory for rows > 12)

Fin Design

A - flat (Al, Cu)	F - flat (SS, CS)
B - corrugated (Al, Cu)	G - corrugated (SS, CS)
C - sine wave (Al, Cu)	H - sine wave (SS, CS, Al, Cu)
D - raised lance (Al)	

Fin Height - minimum of 6 inches to a max of ???

Finned Length - minimum of 6 inches to a max of ???

Evaporator Coil Types



Evaporator coils are designed and engineered for efficient operation with all refrigerants. The performance capabilities are excellent for comfort cooling, process refrigeration, and moisture control dehumidifying.

Direct expansion type evaporator coils are engineered and designed to deliver the maximum possible heat transfer efficiency under all operating conditions. The wide variety of circuiting available offers the opportunity to provide the best circuit for peak coil performance. All evaporator coils are counter flow circuited and equipped with pressure type distributors, and all distributor tubes are of equal length to assure equal distribution of refrigerant to each circuit. Circuiting for face control and row control is also available as standard on a wide variety of coils.

EN

Model Type - EN (Figure 1), is used for applications where capacity control is not required. Single or multiple distributors are used depending on the number of circuits required.

Figure 1 - EN Normal

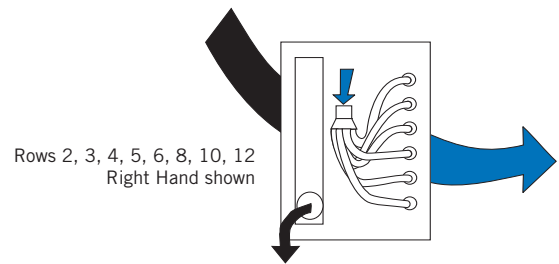

EF

Model Type - EF (Figure 2) is used for face control. Face Control is the simplest form of capacity control. Type EF coils are normally furnished with two distributors and two suction connections offering 50% capacity reduction capabilities.

Figure 2 - EF Face Control

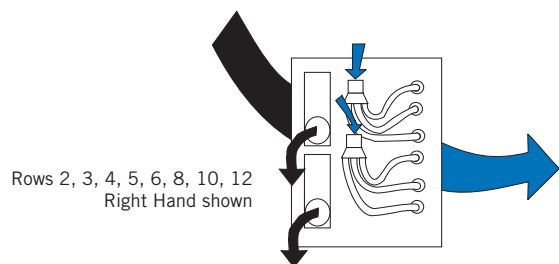

ER

Model Type - ER (Figure 3) offers a row control option for six row evaporators only. These coils are split two rows and four rows which offer approximately a 50% capacity reduction.

Figure 3 - ER Row Control

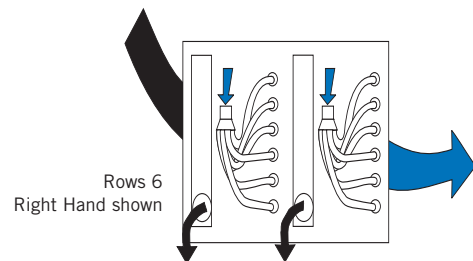

Evaporator Coil Types

EJ

Model Type EJ (Figure 4) coils come with interlaced circuiting. This form of capacity control utilizes two distributors with each feeding every other tube in the first row of the coil. Each distributor has a separate suction connection. Type EJ coils are normally furnished with two distributors and two suction connections offering 50% capacity reduction capabilities.

Figure 4 - EJ Interlaced

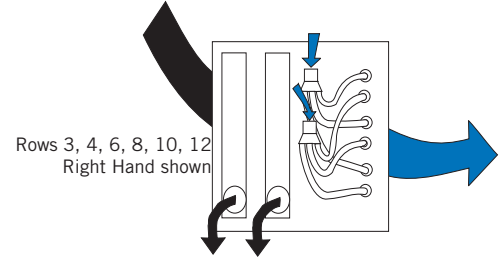

EK

Model Type EK (Figure 5) for applications that require face control and interlaced circuits, this model type is recommended. Interlaced face control normally utilizes four distributors and four suction connections offering 25, 50 and 75% capacity reduction capabilities.

Figure 5 - EK Interlaced Face Control

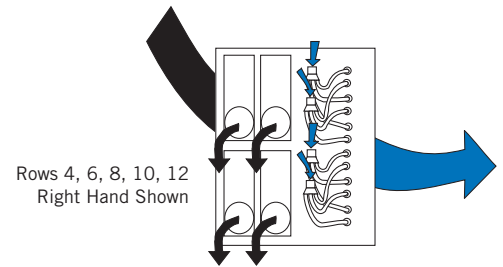
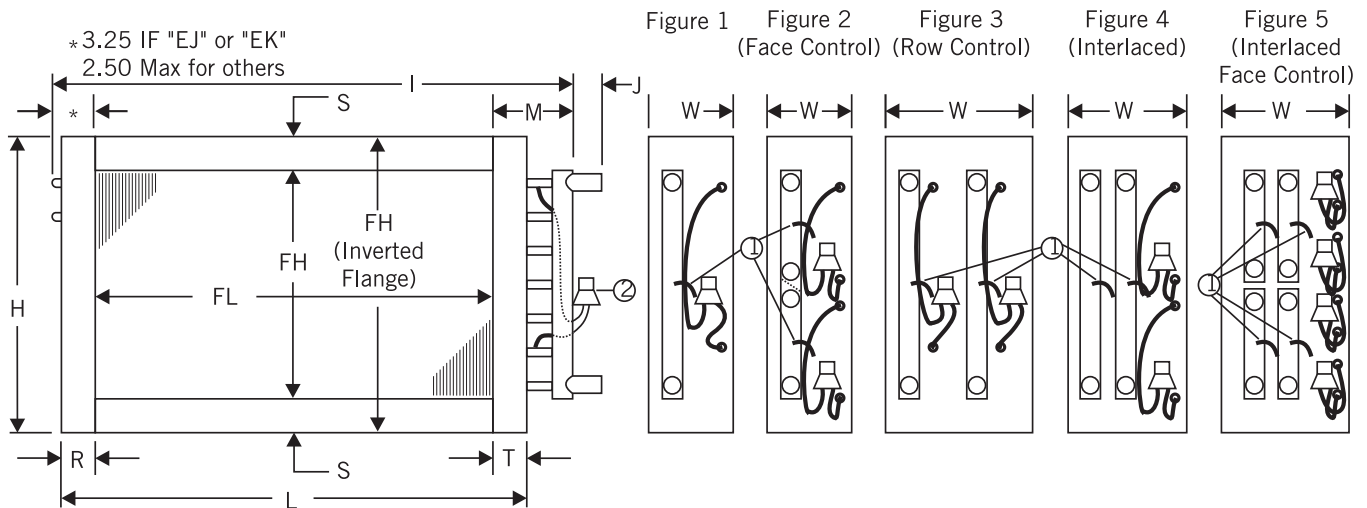

Figure 6 - Indicates the dimensional data needed to quote and build the coil



Evaporator Construction



Connections

Connections are constructed of carbon steel or stainless steel butt-weld or copper sweat material (see Table 1). Liquid supply connections are spaced evenly along the height of the coil and the suction connections are located at the bottom of each compressor circuit unless stated otherwise.

Universal connection coils have two supply suction connections. The actual supply connection should be located at the bottom of the coil on the entering air side when installed to insure proper oil return to the compressor. The coil is both left and right hand. This option is used when the coil hand is not available or if the coil is to be used as a backup for quick replacement of either a right or left hand coil. Using universal connections can cut inventory by providing the flexibility of one coil for either hand connection. Upon installation the extra connections are capped since they are not needed.

Table 1 - Material Options

Material
Copper Sweat UNS # 12200, ASTM B-75, with a H55 Temper
Stainless Steel 304L or 316L ASTM A 312 Sch 40 or Sch 80
Carbon Steel A53A Sch 40
Cupro-nickel UNS# C70600, 90/10, ASTM B-111
Admiralty Brass UNS # C444000, ASTM B-111, Type B

TUBING

Tubing and return bends shall be constructed from seamless copper for standard construction or cupro-nickel, admiralty brass, stainless steel or carbon steel tubing for special applications. Copper tube temper shall be light annealed with a maximum grain size of 0.040 mm and a maximum hardness of Rockwell 65 on the 15T scale. Tubes will be mechanically expanded to form an interference fit with the fin collars. See Table 5 for fin size and material availability. See Tables 1 and 2 for more tube and connection information.

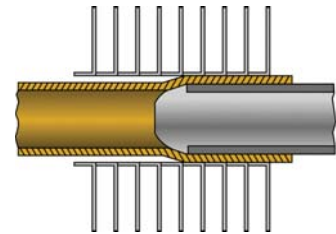

Table 2 - Tubing Information

Tubing Type	Connections	Tube O.D.	Tube Thickness
Copper	Copper Sweat	0.375	0.013, 0.016, 0.020, 0.025, 0.030
		0.500	0.016, 0.022, 0.030
		0.625	0.020, 0.025, 0.035, 0.049
Copper - Rifled	Copper Sweat	0.375	0.012, 0.016
		0.500	0.016
Cupronickel	Copper Sweat	0.625	0.020, 0.035, 0.049
Admiralty Brass	Copper Sweat	0.625	0.049
Stainless Steel	Stainless Steel	0.625	0.035, 0.049, 0.065
Carbon Steel	Carbon Steel	0.625	0.035, 0.049, 0.065



Evaporator Construction



HEADERS

Headers shall be constructed from UNS 12200 seamless copper conforming to ASTM B75 and ASTM B251 for standard applications. Stainless steel headers will be constructed of 304L & 316L (ASTM-A249) Sch-5 or Sch-10. Carbon steel headers shall be constructed of Sch-10 (ASTM-A135A) or Sch-40 (ASTM A53A). End caps shall be die-formed and installed on the inside diameter of the header such that the landed surface area is three times the header wall thickness.

BRAZED COPPER TUBES-TO-COPPER HEADER JOINT

Seamless copper tubes are brazed into heavy gauge seamless drawn copper headers. This combination of similar metals eliminates unequal thermal expansion and greatly reduces stress in the tube-header joint. When possible, intruded tube holes in the header allow an extra landed brazing surface for increased strength and durability. The landed surface area is three times the core tube thickness to provide enhanced header-to-tube joint integrity. All core tubes are evenly extended within the inside diameter of the header no more than 0.12 inch. (See Figure 7)

Figure 7 - Brazed Joint

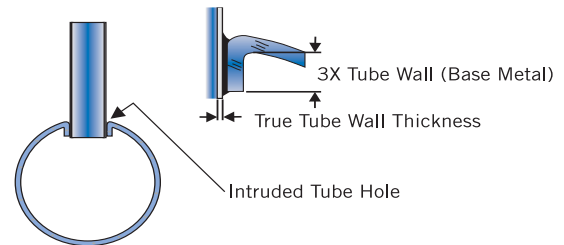

TUBE SUPPORTS

Tube supports will be constructed of the same material as the case, when possible and provided according to the following chart.

Table 3 - Tube Supports

Finned Length (FL)	< 48	> 48 ≤ 96	> 96 ≤ 144	> 144
Tube Supports	0	1	2	4

COIL CASE

Casings and end plates are made from 16-gauge galvanized steel unless otherwise noted. Double-flanged casings on top and bottom of finned height are to be provided, when possible, to allow stacking of the coils. All sheet metal brakes shall be bent to 90 degrees +/- 2 degrees, unless specified otherwise. Coils shall be constructed with intermediate tube support sheets fabricated from a heavy gauge sheet stock of the same material as the case, when possible.

Table 4 - Case Material

Material	Gauge		
	16	14	12
Galvanized Steel, ASTM A-924 and A-653	X	X	*X
Copper ASTM B-152	X	X	X
Aluminum Alloy-3003, Embossed Finish Alloy-5052, Mill Finish (0.125 only)	X	X	X
Stainless Steel 304L (or) 316L, 2B-Finish, ASTM A-240	X	*X	*X

*Not available in pierce and flare header plates

Figure 8 - Case Styles

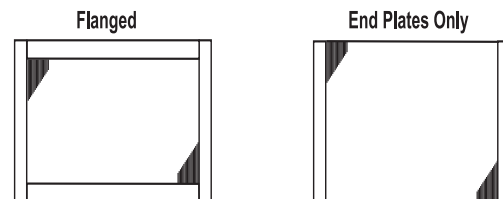

Evaporator Construction



FINS

Coils are built of plate-fin type construction providing uniform support for all coil tubes. Coils are manufactured with die-formed aluminum, copper, cupro-nickel, stainless steel or carbon steel fins (see Table 5) with self-spacing collars, which completely cover the entire tube surface, providing metal-to-metal contact. Fins are self-space die-formed fins 4 through 14 fins/inch with a tolerance of +/- 4%.

Table 5 - Fin Material

Material	Fin Thickness (in.)			
	0.0060	0.0075	0.0095	0.0160
Aluminum Alloy-1100	X	X	X	X
Copper Alloy-110	X	X	X	X
Cupro-nickel 90/10 Alloy-706		X		
Stainless Steel 302-2B		X	X	
Carbon Steel ASTM A109-83		X	X	

Table 6 - Fin Information

Tube O.D.	Fin Material	Fin Thickness	Fin Surface	FPI	
0.375"	AL, CU	0.0060 AL, CU	A, B, C	8-24	
			H	6-18	
		0.0060 AL	D	10-24	
		0.0075 AL, CU	B, C	6-22	
		0.0075 AL	H	6-18	
		0.0095 AL, CU	A, B, C	6-24	
0.5"	AL, CU	0.0060 CU	A, B, C	8-18	
			A, B, C	7-18	
		0.0060	H	8-14	
		0.0075	A, B, C	6-18	
			H	6-14	
		0.0095	A, B, C	6-16	
H	4-14				
0.625"	AL, CU	0.0060 CU	A, B, C	8-14	
		0.0060 AL	A, B, C	6-14	
	AL, CU, CS, SS	0.0075	A, B, C	5-14	
			F	5-14	
			G	6-14	
			G	6-14	
			H	6-14	
			H	6-14	
	AL, CU, CS, SS	0.0095	A, B, C	4-14	
			F	4-14	
			F	5-14	
			G	5-14	
			H	5-14	
			H	6-14	
AL, CU			0.0160	A, B, F, G	4-14



LIQUID OVERFEED EVAPORATORS

Liquid overfeed evaporators perform the same function as a standard DX evaporator except that a mixture of liquid and vapor leaves the coil in lieu of 100% vapor. This is achieved by feeding the evaporator more liquid than can be completely boiled off through the coil. The construction is slightly different in that, instead of having a distributor that properly distributes refrigerant to all the coil's circuits, a liquid overfeed coil has a supply header with an orifice welded into each tap tube. These orifices are largest at the top of the coil and get smaller going to the bottom of the coil. Because refrigerant is so light, gravitational pull has an effect on the distribution of refrigerant in the coil so these orifices act as a way to counteract this force. The liquid connection is located at the top of the coil and the suction connection is located at the bottom of the coil to ensure proper oil return. Since this coil requires a much higher refrigerant charge than a standard DX coil, this application is typically seen in ammonia systems.

There are costs and benefits of this system that should be considered. The added costs involved would be in the initial installation and cost of equipment. This type of coil typically requires a refrigerant pump that will force more liquid through the coil than can be evaporated. Also, since there is a mixture of liquid and vapor leaving the coil (and liquid refrigerant cannot be compressed), this mixture must be separated so that only pure vapor refrigerant is introduced into the compressor. This is typically done in a large tank where the mixture enters the tank at the side. The vapor refrigerant is pulled off the top of the tank while the liquid falls to the bottom. The final additional cost would be the added refrigerant charge due to the tank, extra piping, and increased liquid refrigerant volume in the system.

The benefit can be seen in the annual operation of the system. The liquid overfeed application runs much more efficiently than a standard DX coil. Because there is liquid refrigerant throughout the coil, it is ensured that there will be no dry surface on the interior of the coil tube. With a completely wetted interior tube surface, the refrigerant side heat transfer coefficient is increased. This means that more capacity can be generated out of less surface area. Also, since the refrigerant leaving the coil is at saturation, and not superheated, the temperature of the refrigerant entering the compressor is lowered. This results in lower compressor discharge temperatures, which can both extend the life of the compressor and have the compressor run more efficiently.

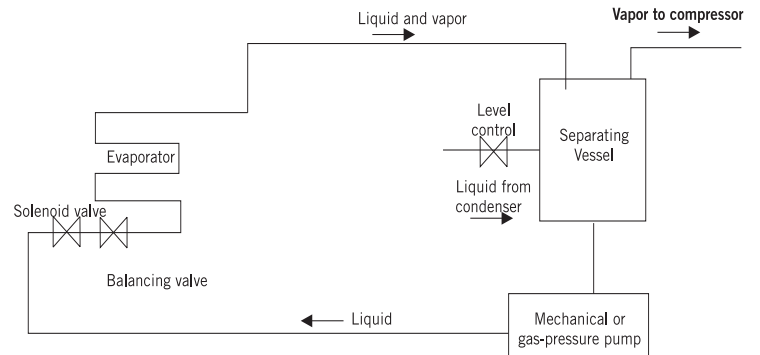

GENERAL FORMULAS

TOTAL BTUH (Air Cooling)

$$\text{Total BTUH} = 4.5 \times \text{SCFM} \times (\text{Total Heat Ent. Air} - \text{Total Heat Lvg. Air})$$

Where 4.5 = Density Std. Air x Min./Hr.
 Density Std. Air = 0.075 lbs./cu. ft.
 Min./hr. = 60

SENSIBLE BTUH (Air Cooling)

$$\text{Sensible BTUH} = 1.08 \times \text{SCFM} \times (\text{Ent. Air DB} - \text{Lvg. Air DB})$$

Where 1.08 = (Specific heat of air) x (Minutes/Hr.) x Density Std. Air
 Specific heat = 0.24 btu/lb.F
 Min./hr. = 60
 Density Std. Air = .075 Lbs./cu. ft.

SENSIBLE TOTAL RATIO

$$\text{S/T Ratio} = \text{Sensible BTUH} \div \text{Total BTUH}$$

LEAVING AIR TEMPERATURE (cooling)

$$\text{Lvg Air Temp.} = \text{Ent. Air Temp.} - (\text{Sensible BTUH} \div (1.08 \times \text{SCFM}))$$

FACE AREA

$$\text{FA (Sq. Ft.)} = (\text{Fin Height} \times \text{Finned Length}) \div 144$$

FACE VELOCITY (FPM)

$$\text{FPM} = \text{SCFM} \div \text{Face Area (sq. ft.)}$$

MBH PER SQUARE FOOT OF FACE AREA

$$\text{MBH/Sq. Ft.} = \text{Total BTUH} \div (\text{Face Area (Sq. Ft.)} \times 1000)$$

Standard Conditions:

Temperature = 70°F
 Pressure = 14.69 psi
 Density = 0.075 lb/ft³

BASIC VAPOR COMPRESSION CYCLE

Diagram 1 - Vapor Compression Cycle

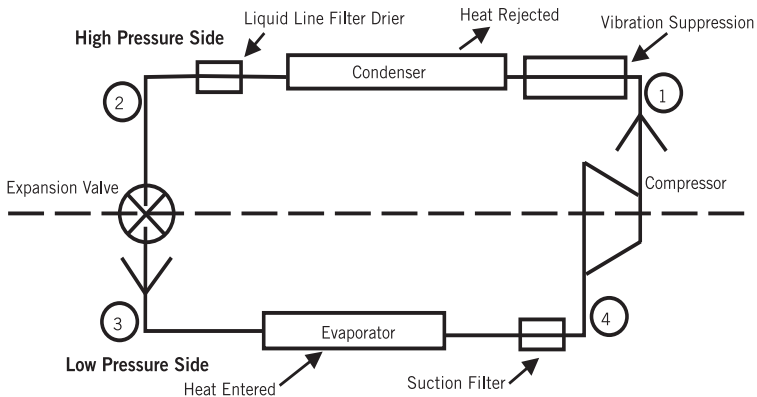

The basic refrigeration cycle is a continuous loop of changing refrigerant pressures and temperatures of the refrigerant to cause heat transfer from the surrounding air stream.

1. As the refrigerant leaves the evaporator, it has absorbed heat and, at this point, is a low temperature, low-pressure superheated vapor.
2. The suction of the compressor draws the refrigerant back to the compressor the gas is highly compressed so that the corresponding temperature to pressure relationship is well above the ambient temperature surrounding the condenser coil.
3. This high pressure, high temperature gas vapor is passed through the condenser coil where the ambient air blows across the coil. Since the ambient air is at a much lower temperature than the high temperature refrigerant vapor, the vapor loses heat to the air stream and subsequently condenses in the condenser coil until the state of the total amount of the refrigerant changes into a sub-cooled liquid.
4. This high-pressure, sub-cooled liquid then travels as a liquid to the expansion valve, where the pressure is lowered quickly, resulting in the liquid refrigerant “flashing” so that both pressure and temperature are reduced significantly. This refrigerant mixture is now mostly liquid but also contains some vapor bubbles from the rapid lowering of the pressure as it passed through the expansion valve.
5. The refrigerant then passes into a refrigerant distributor, where the distributor tubes independently introduce the liquid mixture into the evaporator. Each distributor tube feeds an independent circuit.
6. The refrigerant temperature at this point should have dropped to a point well below the temperature of the air passing over the evaporator coil and will continue to vaporize (evaporate) in the evaporator, as it absorbs heat from the air stream. It should continue to do this until all of the liquid has been converted into a superheated vapor as it leaves the evaporator and is once again pulled into the suction line and returned to the compressor for another cycle.

Important in this cycle are the changes in pressure that results in changes in the pressure/temperature relationship of the refrigerant. As the temperature of the refrigerant changes it is subjected to air being moved over either the evaporator or condenser where the temperature difference between the refrigerant and air stream result in a transfer of heat either into or away from the refrigerant.

As this occurs, the refrigerant will change state in the cycle from liquid to vapor and back again through the use of the compressor and expansion valve, where the change in pressure is accomplished. The term used to describe this is a “two phase” cycle.

For more information, please contact:

Luvata Grenada LLC
Grenada, MS, USA
Phone +662 229 4000
Fax +662 229 4212

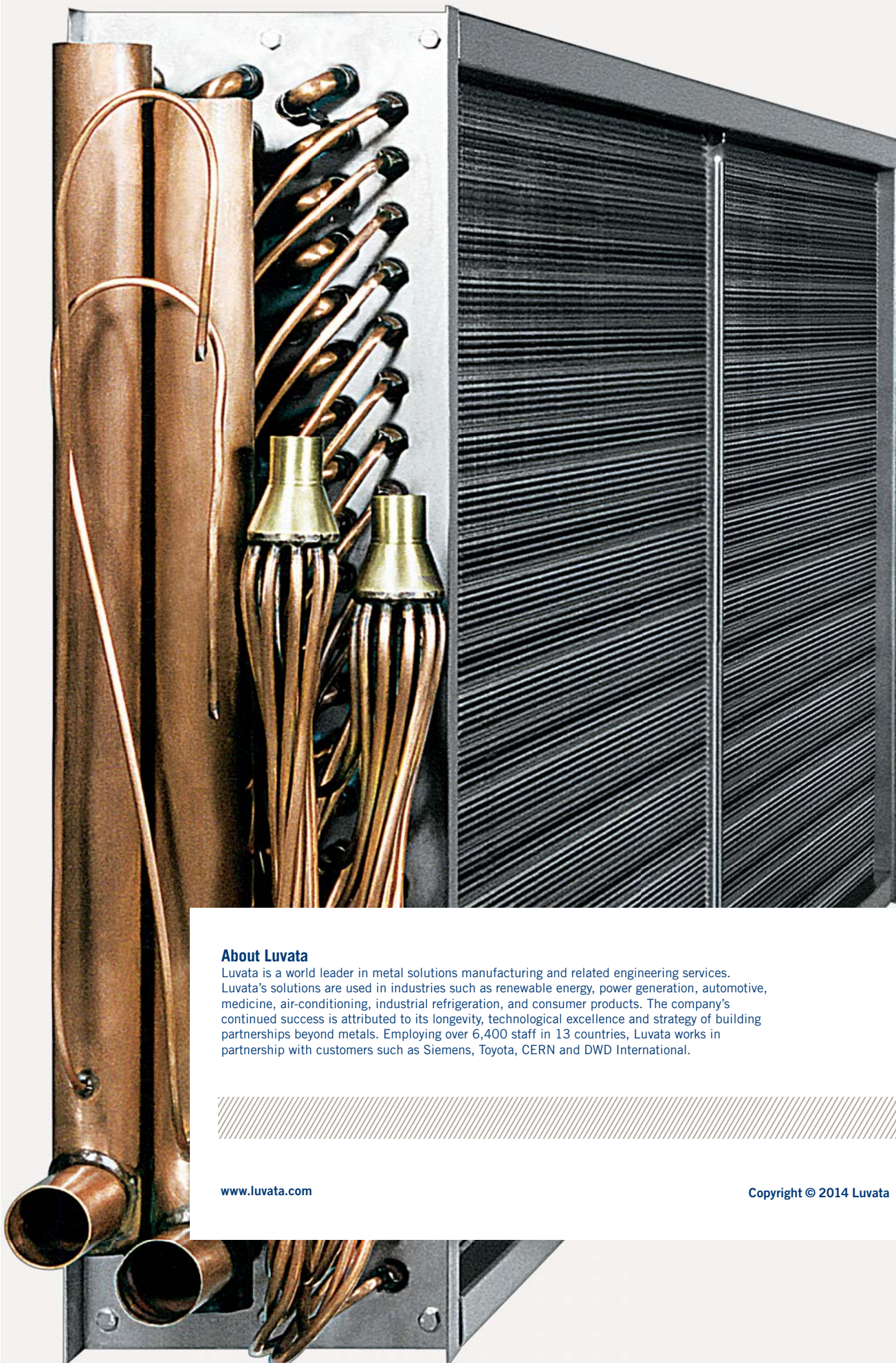

About Luvata

Luvata is a world leader in metal solutions manufacturing and related engineering services. Luvata's solutions are used in industries such as renewable energy, power generation, automotive, medicine, air-conditioning, industrial refrigeration, and consumer products. The company's continued success is attributed to its longevity, technological excellence and strategy of building partnerships beyond metals. Employing over 6,400 staff in 13 countries, Luvata works in partnership with customers such as Siemens, Toyota, CERN and DWD International.

www.luvata.com

Copyright © 2014 Luvata