

Customer \_\_\_\_\_ Customer P.O. Number \_\_\_\_\_

Job \_\_\_\_\_

Written by \_\_\_\_\_ Date \_\_\_\_\_

Approved by \_\_\_\_\_ Date \_\_\_\_\_

#	TAG	QTY	MODEL NUMBER						FIG#	CASING
			TYPE	FPI	ROWS DEEP	FIN	FH	FL		
1										
2										
3										
4										

#	DIMENSIONAL DATA												
	CONNECTION								FLANGES				W
	SIZE	A	C	E	H	I	L	M	R	S	T		
1													
2													
3													
4													

GENERAL OPTIONS	
<input type="checkbox"/>	Label Kit
<input type="checkbox"/>	Mounting Holes
<input type="checkbox"/>	Corrosion Resistant Coating
<input type="checkbox"/>	0.125" Dole Vent & Drain

CONN. OPTIONS	
<input type="checkbox"/>	FPT
<input type="checkbox"/>	0.75"
<input type="checkbox"/>	1"

MATERIALS OF CONSTRUCTION				
FINS	AL	CU	CS	St Stl
TUBES	CU	CuNi	CS	St Stl

MATERIALS OF CONSTRUCTION				
CONN	Cu Sweat	CS	St Stl	Wrot Cu
CASING	AL	Galvanized Steel	Stainless Steel	

REMARKS:

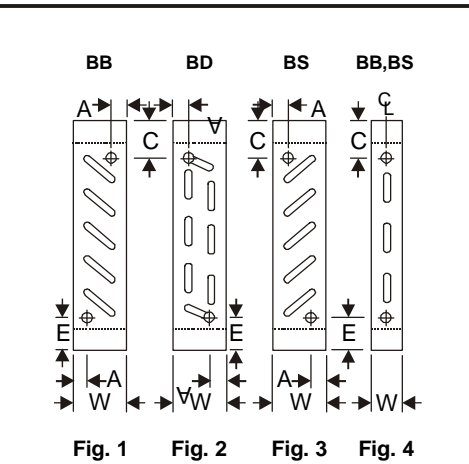
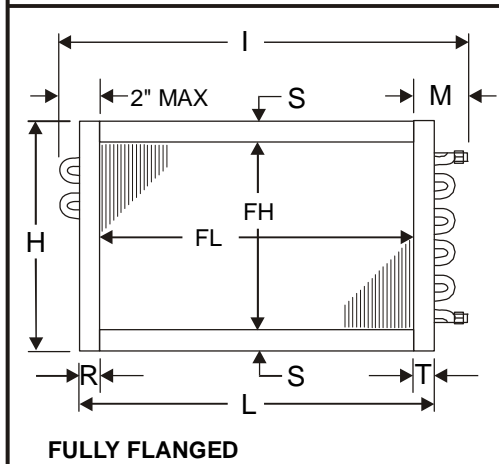
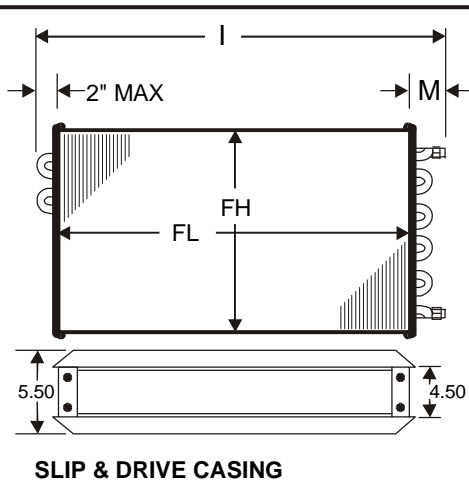
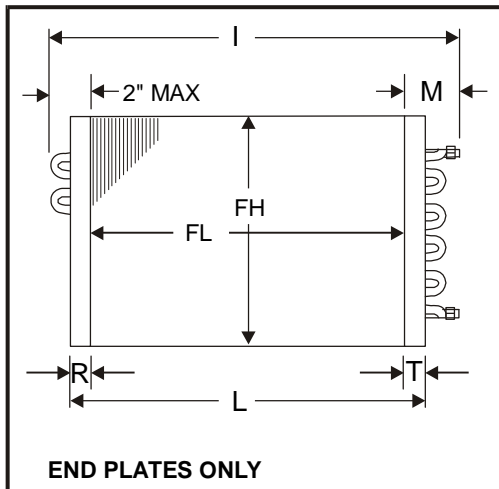

**GENERAL NOTES**

1. Mounting holes are optional for Fully Flanged and End Plates Only. 0.375" diameter holes on 6" centers from the centerline of the fin height and finned length are typical for all flanges. Not available when S < 0.75".
2. All dimensions are in inches.
3. The water should enter the coil through the lower connection for proper fluid flow.
4. Intermediate tube supports are fabricated from heavy gauge stock and supplied per the chart below.

Finned Length (FL)	Tube Supports
≤ 48	0
> 48 ≤ 96	1